

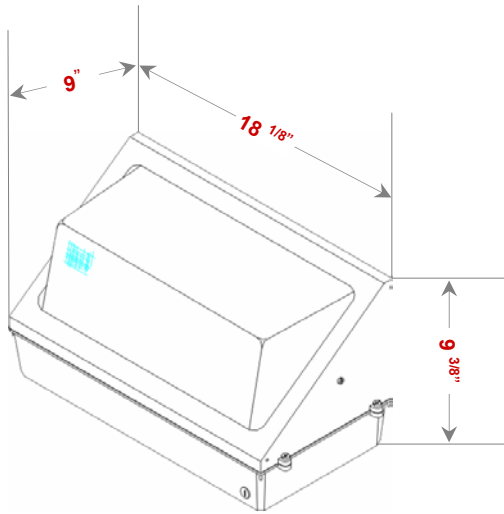

LARGE HID WALL PACK (WIRED)



CONSTRUCTION:

- Die Cast Bronze Housing and Lens Frame
- Hinged From Frame
- Heat Resistant Borosilicate Glass Reflector
- Includes Porcelain Mogul Base Socket
- Includes Ballast & Lamp as shown

APPLICATIONS:

- Ideal for Security and Perimeter Lighting
- For Warehouse, Schools, Tunnels, and Shopping Complexes
- Commercial, Industrial, and Institutional Lighting

ELECTRICAL CHARACTERISTICS

Model #	Voltage	Wattage	Hertz	Lamp Type	Ballast Type
<i>JWP250HPSQVL-PK</i>	<i>Quad</i>	<i>250W</i>	<i>60Hz</i>	<i>HPS</i>	<i>CWA-HPF</i>
<i>JWP250MHQVL-PK</i>	<i>Quad</i>	<i>250W</i>	<i>60Hz</i>	<i>MH</i>	<i>CWA-HPF</i>
<i>JWP250HPS220/50L-PK</i>	<i>120/220/240V</i>	<i>250W</i>	<i>50Hz</i>	<i>HPS</i>	<i>CWA-HPF</i>
<i>JWP250MH220/50L-PK</i>	<i>120/220/240V</i>	<i>250W</i>	<i>60Hz</i>	<i>MG</i>	<i>CWA-HPF</i>

PRODUCT DIMENSIONS

Width	Height	Depth
18"	9"	9 3/4"